

# Reed Basket Kit

Soak reed in water for 10 minutes, then follow these simple steps.

## BOTTOM CONSTRUCTION

### Figures 1 & 2

1. Insert short, heavy reed (stake) into each hole in base. Allow  $2\frac{1}{4}$ " to extend beyond underside.
2. Flip base over so that  $2\frac{1}{4}$ " allowances are on top side

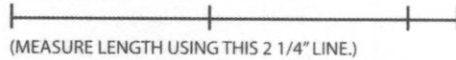

3. Weave one  $2\frac{1}{4}$ " allowance in front of next one and behind third. Continue until all allowances are interwoven.

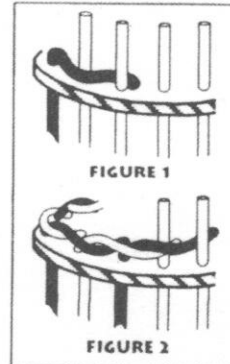

## TOP CONSTRUCTION

### Figure 3

4. Flip base over again so that woven allowances are on bottom side.
5. Insert thin reed strand between two stakes and draw strand in front of first stake, behind second stake, in front of third stake, behind fourth, and so on until end of stands is reached.
6. Fashion stakes to desired shape.
7. Insert second thin reed strand and follow weaving method in step 5.

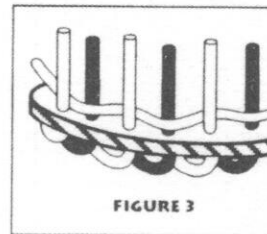

## EDGING

### Figure 4

8. When weaving is completed, bend first stake (A) in front of second stake (B), then insert next to third stake (C). Repeat process with remaining stakes to shape scalloped edging.

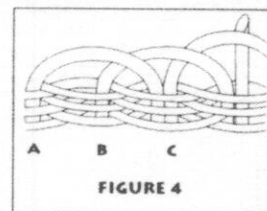

Basket may be coated with varnish or polyurethane for shiny, protective covering. Kit contains materials for one basket.

# # 3 5 0

# Stool Kit

**NOTE: THE FRAME MUST BE ASSEMBLED, GLUED AND ALLOWED TO DRY OVERNIGHT, ON A FLAT SURFACE, BEFORE WEAVING THE SEAT.**

## LIST OF CONTENTS:

4 LEGS

8 DOWEL RODS

1 ROLL OF JUTE TWINE

## ASSEMBLY INSTRUCTIONS:

1. LAY OUT THE LEGS AND DOWEL RODS ON A FLAT SURFACE.
2. PUT A LARGE DROP OF GLUE IN EACH HOLE OF LEGS, ONE LEG AT A TIME.
3. PUSH IN DOWEL RODS UNTIL FRAME IS ASSEMBLED AS SHOWN. A Mallet OR HAMMER MIGHT BE NEEDED.
4. **ALLOW GLUE TO DRY COMPLETELY, PREFERABLY OVERNIGHT.**
5. LOCATE OUTSIDE END OF THE TWINE AND TIE OFF ON A DOWEL ROD NEXT TO A LEG. USE A CLOVE HITCH KNOT.
6. TAKE THE TWINE INSIDE AND AROUND THE LEG. GO UNDER THE DOWEL ROD, OVER THE TOP TO THE OPPOSITE DOWEL ROD.
7. GO OVER THE TOP AND UNDER THE DOWEL ROD AND AROUND THE LEG.
8. **PULL THE TWINE TIGHT EACH TIME YOU WRAP AROUND A DOWEL ROD.**
9. CONTINUE UNTIL ALL OF THE SEAT TOP IS COVERED. CUT THE END AND TIE UNDER SEAT.

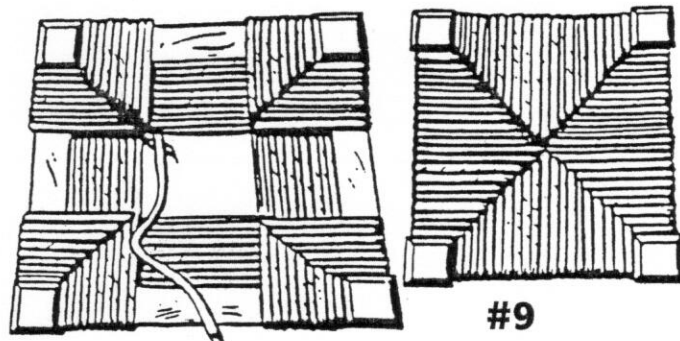
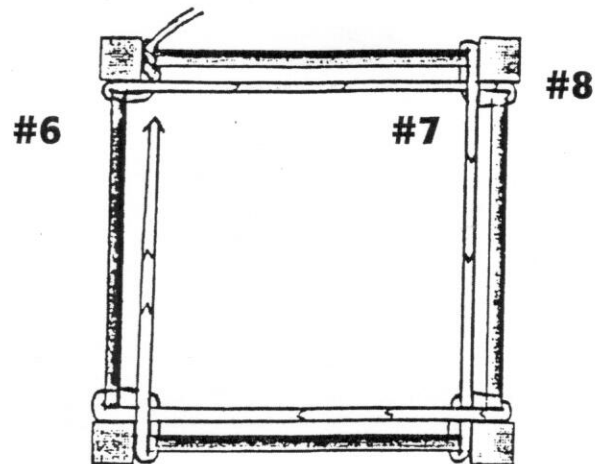
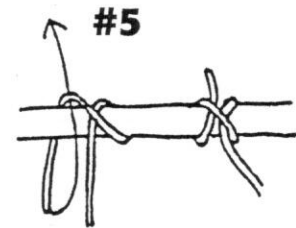
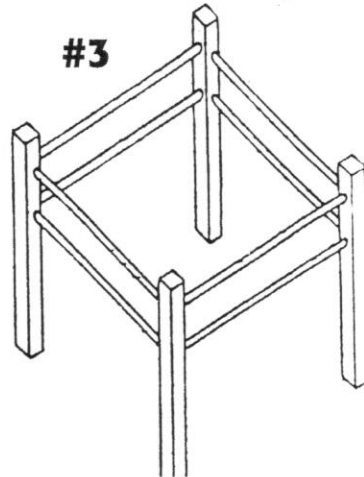

**CAUTION: THE TWINE SEAT WILL NOT SUPPORT MORE THAN 25 LBS.**



# # 202

# Large Leather Knife Pouch Kit

**IMPORTANT: COMPLETE ALL TOOLING, DYEING AND FINISHING, THEN ATTACH SNAP BEFORE ASSEMBLY.**

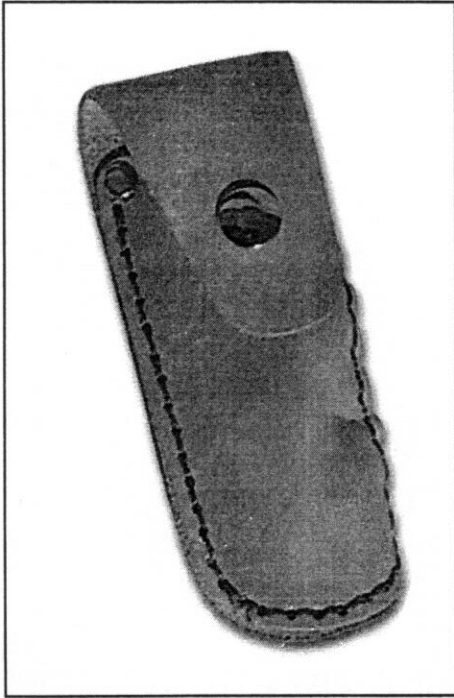

### KIT CONTAINS:

- A. BELT STRAP
- B. BACK PIECE
- C. FRONT PIECE
- D. NEEDLE AND THREAD
- E. SNAP PARTS (4)
- F. RIVETS (2)

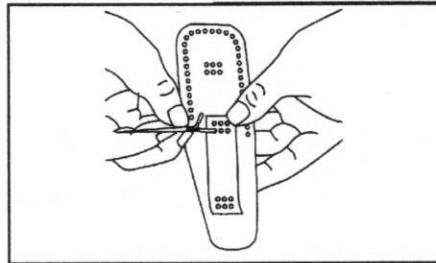
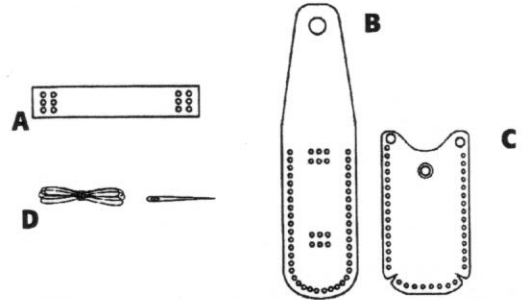

1. ATTACH THE BELT STRAP TO BACK PIECE BY ALIGNING THE HOLES IN THE STRAP WITH THE TOP SET OF HOLES IN THE BACK PIECE, AS SHOWN, WITH THE SMOOTH SIDES TOGETHER.

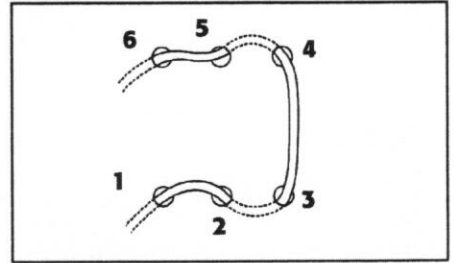

2. WITH WAXED THREAD, COME UP THROUGH HOLE 1 TO TOP SIDE OF LEATHER LEAVING A TAIL OF 2" ON UNDERSIDE. GO DOWN THROUGH HOLE 2 AND BACK UP THROUGH 3, DOWN THROUGH 4, UP THROUGH 5 AND DOWN THROUGH 6.

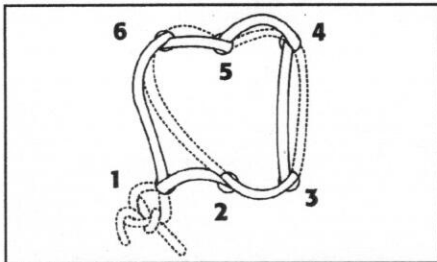

3. FROM HOLE 6 COME UP THROUGH HOLE 2, GO DOWN THROUGH HOLE 3, BACK UP THROUGH 4, DOWN THROUGH 5, AND BACK UP THROUGH 6. GO DOWN THROUGH HOLE 1 AND TIE OFF TIGHTLY. TRIM OFF EXCESS THREAD AND TAP KNOT WITH A Mallet.

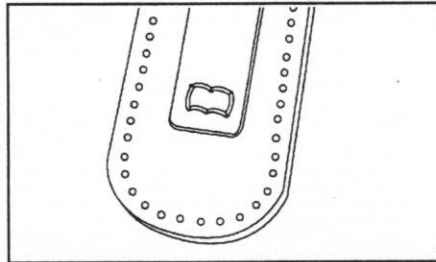

4. NOW ALIGN THE HOLES IN THE OTHER END OF THE STRAP TO THE BOTTOM SET OF HOLES IN THE BACK, WITH THE ROUGH SIDE OF THE STRAP ON THE SMOOTH SIDE OF THE BACK PIECE. STITCH ON THE STRAP AS IN STEPS 2 AND 3.

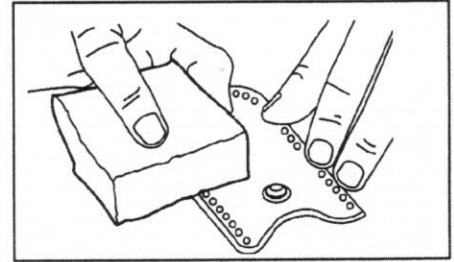

5. BEFORE STITCHING YOUR KNIFE POUCH TOGETHER, APPLY WATER TO THE FRONT PIECE OF THE KNIFE POUCH. THIS MAKES IT EASIER TO FORM FRONT PIECE TO THE BACK PIECE. STITCH IT TOGETHER WHILE THE LEATHER IS DAMP.

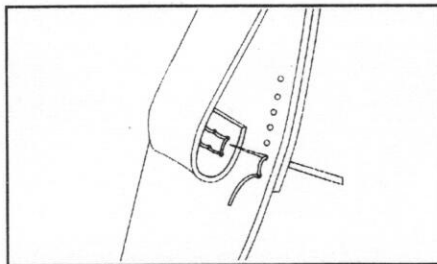

6. LEAVE BOTH LARGE HOLES ON FRONT AND BACK PIECE OPEN FOR INSTALLATION OF THE RIVETS. IN STITCHING THE FRONT PIECE TO THE BACK, YOU WILL BEGIN IN THE FIRST SMALL HOLE LEAVING 2" OF THREAD ON THE BACKSIDE OF THE POUCH FOR THE TIE OFF. GO THROUGH HOLE 2, THEN BACK THROUGH HOLE 1, GOING THROUGH HOLE 1 TWICE. CONTINUE STITCHING IN AND OUT AROUND POUCH.

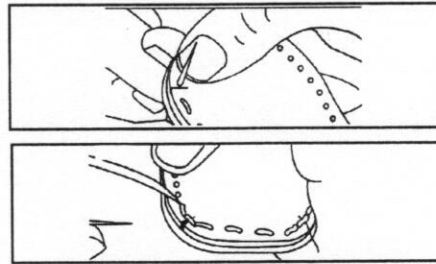

7. WHEN YOU REACH HOLE 16, THERE WILL BE A NOTCH BETWEEN HOLES 16 AND 17. WHEN STITCHING THESE TOGETHER, PULL THEM TOGETHER TIGHTLY AND KEEP EDGES EVEN. SEE A. STITCH OVER THE NOTCH TWICE FOR STRENGTH. REPEAT FOR THE NOTCH BETWEEN HOLES 26 AND 27.

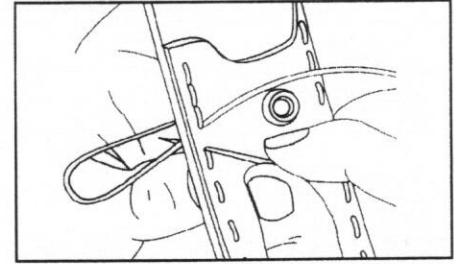

8. WHEN YOU REACH THE LAST HOLE, STITCH THROUGH IT TWICE AND THEN STITCH BACK ACROSS FILLING IN THE ALTERNATIVE STITCHES. WHEN YOU HAVE STITCHED BACK TO THE BEGINNING STITCH, TIE THE TWO ENDS TOGETHER ON THE BACK SIDE OF THE POUCH AND TAP KNOT WITH A Mallet. INSTALL RIVETS.

©YORK RESOURCES, LLC / 800-736-3056

CAUTION: CHOKING HAZARD, MAY CONTAIN SHARP EDGES/POINTS AND SMALL PARTS. AGES 8 AND ABOVE.



PROUDLY MADE IN THE USA